



## Magnetic Inductive Flow Sensor **induQ**<sup>®</sup>

Series VMZ.2

Types VMZ03 / VMZ06 / VMZ08 / VMZ15 / VMZ20 / VMZ25



Table of contents	page
0 About this operating manual.....	3
1 Device description.....	4
1.1 Delivery, unpacking and accessories.....	4
1.2 Intended use.....	5
1.3 Exclusion of liability.....	5
2 Safety instructions.....	6
3 Construction and function.....	7
4 Installation of VMZ.2.....	8
4.1 Installation instructions.....	9
4.2 Assembly.....	10
5 Electrical connection.....	11
5.1 Wirings.....	12
6 Commissioning and measuring operation.....	13
6.1 Commissioning.....	13
6.2 Switching on and off.....	13
6.3 Measuring operation.....	13
7 Maintenance and cleaning.....	14
7.1 Return shipment to the manufacturer.....	14
8 Disassembly and disposal.....	15
9 Technical data.....	16
9.1 Characteristics VMZ.2.....	16
9.2 Materials table.....	17
9.3 Dimensions.....	18

induQ® is a registered trademark of SIKA Dr. Siebert & Kühn GmbH & Co. KG.

#### Copyright notice:

The reproduction, distribution and utilization of this operating manual as well as the communication of its contents to others without express authorization is prohibited. Offenders will be held liable for the payment of damages. All rights reserved in the event of the grant of a patent, utility model or design.

## 0 About this operating manual

- The operating manual is aimed at specialists and semi-skilled personnel.
- Before each step, read through the relevant advice carefully and keep to the specified order.
- Thoroughly read and understand the information in the section “Safety instructions”.

If you have any problems or questions, please contact your supplier or contact us directly at:



Dr. Siebert & Kühn GmbH & Co. KG  
 Struthweg 7-9 • D - 34260 Kaufungen  
 ☎ +49 5605 803-0 • 📠 +49 5605 803-555  
 info@sika.net • www.sika.net

### Hazard signs and other symbols used:



**WARNING! / CAUTION! Risk of injury!**

This sign indicates dangers that cause personal injuries that can lead to health defects or cause considerable damage to property.



**CAUTION! Electric current!**

This sign indicates dangers which could arise from handling of electric current.



**CAUTION! Material damage!**

This sign indicates actions which could lead to possible damage to material or environmental damage.



**ADHERE TO OPERATING MANUAL!**



**NOTICE!**

This symbol indicates important notices, tips or information.



**NO DOMESTIC WASTE!**

The device must not be disposed of together with domestic waste.



Pay attention to and comply with information that is marked with this symbol.



Follow the specified instructions and steps. Adhere to the given order.



Check the specified points or notices.



Reference to another section, document or source.



Item.

## 1 Device description

The induQ® of the VMZ.2 series from SIKA is a flow sensor without moving parts. The measurement is performed using magnetic induction.

The VMZ.2 is used for measuring or metering water and electrically conductive fluids. The compact design and independence from the intake and discharge sections allows the VMZ.2 to be used under a variety of conditions.

### Versions:

The VMZ.2 is available in different nominal sizes from DN 3 to DN 25.

### Type plate:

You can find the type plate on the back of the VMZ.2.

It contains the most important technical data.

## 1.1 Delivery, unpacking and accessories

All units have been carefully checked for their operational reliability before shipment.

- Immediately after receipt, please check the outer packaging for damages or any signs of improper handling.
- Report any possible damages to the forwarder and your responsible sales representative. In such a case, state a description of the defect, the type and the serial number of the device.  
Report any in-transit damage immediately. Damage reported later shall not be recognized.

### Unpacking:

- ↪ Carefully unpack the unit to prevent any damage.
- ↪ Check the completeness of the delivery based on the delivery note.

### Scope of delivery:

- 1x VMZ.2 according to the order data.
- 1x Operating manual.

### IMPORTANT!



- ↪ Use the type plate to check if the delivered unit corresponds to your order.
- ↪ In particular, for devices with electrical components, check to see if the correct power supply voltage is specified.

**Accessories:**

- Connection cable with moulded M12x1 coupling socket.
- M12x1 coupling socket as component.

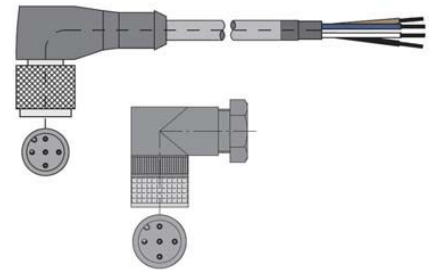
**1.2 Intended use**

The magnetic inductive flow sensor VMZ.2 must only be used for measuring and metering liquids with a minimum conductivity of 20  $\mu\text{S}/\text{cm}$ .

**WARNING! No safety component!**

The magnetic inductive flow sensor of the series VMZ.2 is no safety component in accordance with Directive 2006/42/EC (Machine Directive).

↪ Never use the VMZ.2 as a safety component.

The operational safety of the device supplied is only guaranteed by intended use. The specified limits (→ § 9 “Technical data”) may under no circumstances be exceeded.

Before installing the device, check that the wetted materials of the device are compatible with the media being used (→ § 9.2 “Materials table”).

Measuring tube empty (or partially filled). / Conductivity too low.



The green LED may blink irregularly if the measuring tube of the VMZ.2 is empty or partially filled or if the conductivity of the fluid being used is too low. Random pulses will be present at the output, but they do not represent an actual flow.

↪ Ensure that the measuring tube of the VMZ.2 is always completely filled (→ § 4.1 “Installation instructions”).

↪ Ensure that the conductivity of the fluid is at least 20  $\mu\text{S}/\text{cm}$ .

**1.3 Exclusion of liability**

We accept no liability for any damage or malfunctions resulting from incorrect installation, inappropriate use of the device or failure to follow the instructions in this operating manual.

## 2 Safety instructions

Before you install the VMZ.2, read through this operating manual carefully. If the instructions contained within it are not followed, in particular the safety guidelines, this could result in danger for people, the environment, and the device and the system it is connected to.

The VMZ.2 corresponds to the state-of-the-art technology. This concerns the accuracy, the operating mode and the safe operation of the device.

In order to guarantee that the device operates safely, the operator must act competently and be conscious of safety issues.

SIKA provides support for the use of its products either personally or via relevant literature. The customer verifies that our product is fit for purpose based on our technical information. The customer performs customer- and application-specific tests to ensure that the product is suitable for the intended use. With this verification all hazards and risks are transferred to our customers; our warranty is not valid.

### Qualified personnel:

- The personnel who are charged for the installation, operation and maintenance of the VMZ.2 must hold a relevant qualification. This can be based on training or relevant tuition.  
The personnel must be aware of this operating manual and have access to it at all times.
- The electrical connection should only be carried out by a fully qualified electrician.

### General safety instructions:

- In all work, the existing national regulations for accident prevention and safety in the workplace must be complied with. Any internal regulations of the operator must also be complied with, even if these are not mentioned in this manual.
- Degree of protection according to EN 60529:  
Please ensure that the ambient conditions at the site of use does not exceed the requirements for the stated protection rating (→ § 9 "Technical data").
- Prevent freezing of the medium in the device with appropriate measures.
- Only use the VMZ.2 if it is in perfect condition. Damaged or faulty devices must be checked immediately and, if necessary, replaced.
- When fitting, connecting and removing use only suitable appropriate tools.
- Do not remove or obliterate type plates or other markings on the device, as otherwise, the warranty is rendered null and void.

### Special safety instructions:

- Crystallizing liquids:  
Liquids, which crystallize when dried out, can cause a malfunction of the VMZ.2.
  - ↳ Make sure that the VMZ.2 is not run dry.
  - ↳ Prevent the crystallization of the fluid in the device by taking appropriate measures.

Further warnings that are specifically relevant to individual operating procedures or activities can be found at the beginning of the relevant sections of this operating manual.

### 3 Construction and function

#### Components:

- ① Housing:  
The Housing consists of plastic and has the IP65 degree of protection.
- ② Electrical connection:  
The electrical connection is made via 4-pin plug M12x1.
- ③ Process connection:  
The process connections are available in different sizes.
- ④ Operation / flow indicator LED.



#### Construction:

The measuring tube with its earthing sleeves and electrodes passes through the housing and forms the external process connection of the VMZ.2.

A magnetic field for the measurement process is generated inside the housing, which also contains the sensor and signal conditioning circuitry.

The two stainless steel electrodes are located in the middle of the measuring tube between the earthing sleeves.

The VMZ.2 does not need any moving parts to make measurements. The inside of the measuring tube is completely open, allowing the fluid to flow unhindered through the measuring tube.

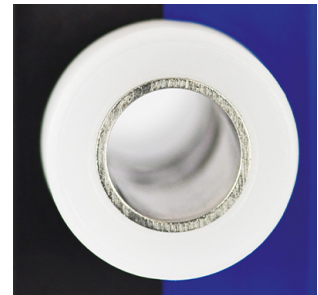

#### Function:

The magnetic inductive flow sensor functions according to the induction principle. A DC voltage is generated by the movement of a conductor in a magnetic field:

The measuring tube of the VMZ.2 is located in a magnetic field (B).

An electrically conductive medium (V) flows through the measuring tube. The positive and negative charge carriers are oppositely deflected.

A voltage (U) is generated at right angles to the magnetic field, which is picked up by the two electrodes. Thereby, the induced voltage is proportional to the average flow velocity of the liquid.

The electronics of the VMZ.2 converts the induced voltage into a flow-proportional frequency signal.

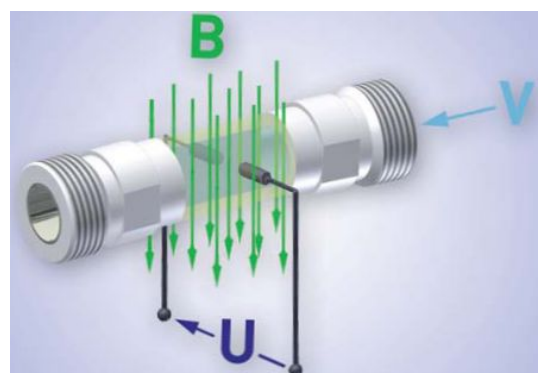

## 4 Installation of VMZ.2

Before installing, check that

- the wetted materials of the device are suitable for the media being used (→ § 9.2 “Materials table”).
- the equipment is switched off and is in a safe and de-energised state.
- the equipment is depressurised and has cooled down.



### SUITABLE TOOLS:

↪ Use only suitable tools of the correct size.



**4.1 Installation instructions**



**CAUTION! Risk of malfunction due to external magnetic fields!**

Magnetic fields close to the device can cause malfunctions and should be avoided.

↪ Ensure that no external magnetic fields are present at the installation site of the VMZ.2.

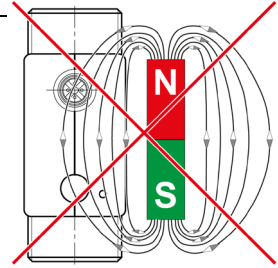

- The VMZ.2 can always be installed anywhere along the pipeline. However, straight sections of piping are preferable.

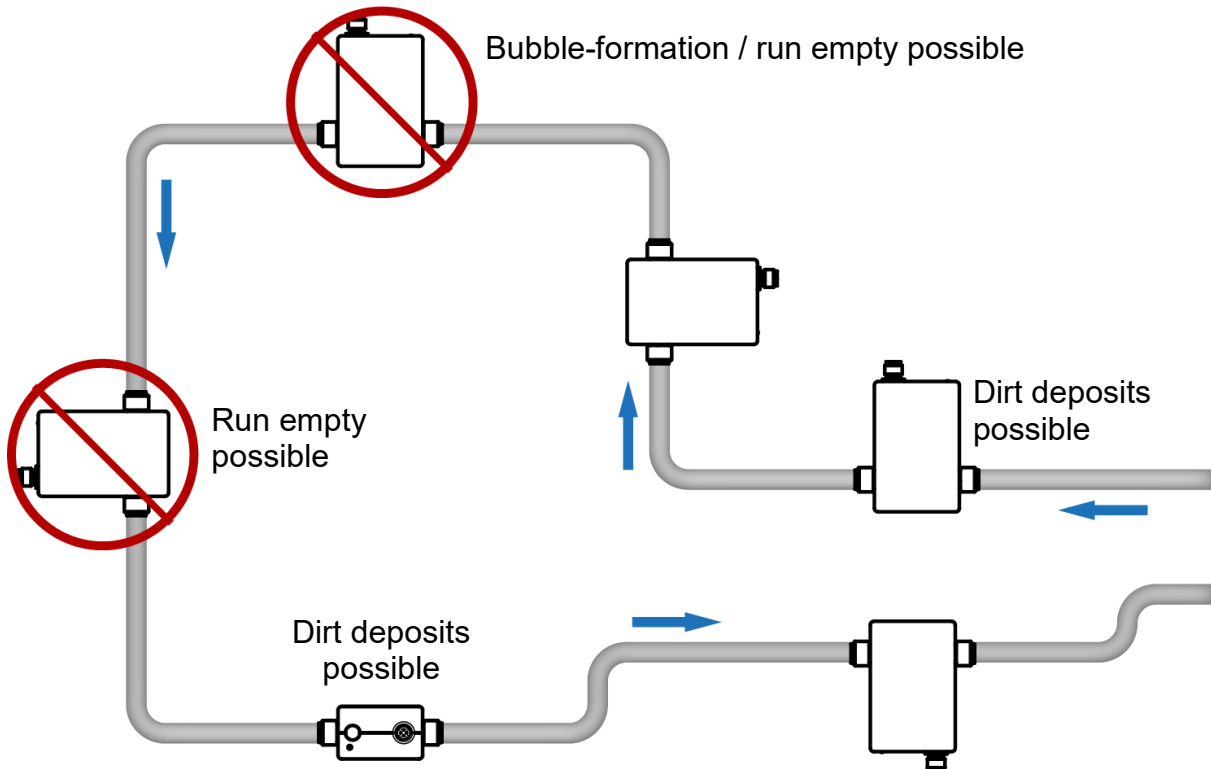

- Installation can occur in horizontal and vertical pipes. The flow sensor is only suitable for application in completely filled pipe systems.
- As a matter of principle, magnetic inductive flow sensors are widely independent from the flow profile. An inlet section is not necessary. To reach a most highly accuracy of the measurement, you should use straight inlet and outlet sections according to the nominal width (DN). The inlet section has to be at least 10 x DN; the outlet section 5 x DN in order to achieve the specified accuracy.
- The inlet and outlet sections and the gaskets must have the same or a slightly larger inside diameter than the measuring tube in order to achieve the specified accuracy.
- If two or more VMZ.2 devices are used side by side, maintain a separation of at least 2.5 cm between adjacent devices. If adjacent devices are too close together, operation of both devices may be impaired due to mutual interference.

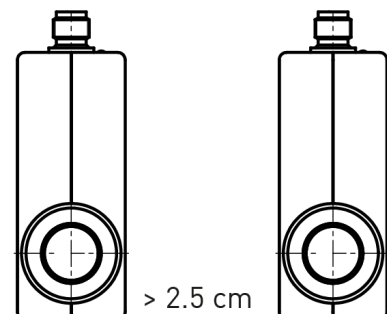

## 4.2 Assembly

The VMZ.2 is installed directly into the pipeline. The compact design and lightweight of the unit make wall mounting unnecessary.



### IMPORTANT NOTICES:

- Only use suitable gaskets for installation.
- Observe the flow direction indicated on the type plate.
- Observe the mounting dimensions (→ § 9.3 “Dimensions”).

- ↪ Select an appropriate location for installation (→ § 4.1 “Installation instructions”).

To ensure the best possible measuring accuracy, a vertical installation position with increasing flow is preferable (no collecting of dirt deposits).

- ↪ Install the appropriate screwed connections at the installation location.
- ↪ Insert the VMZ.2 together with the gaskets.
- ↪ Screw the union nuts of the screwed connection onto the process connections of the VMZ.2.
- ↪ Ensure that an air gap remains between the union nut and the housing. If the union nuts are screwed right up to the housing, the VMZ.2 may be damaged.

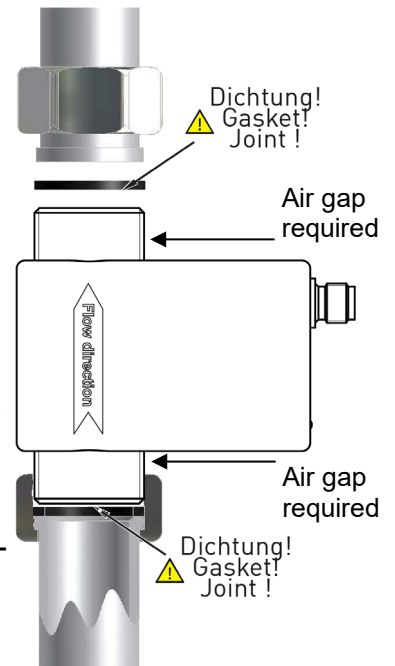

### CAUTION! Material damage!

#### Pay attention to maximum torque.

While tightening, counter the VMZ.2 only by hand! If you use an open-end or a pipe wrench, the VMZ.2 can be damaged.



### Maximum torque

VMZ03		VMZ06/08		VMZ15		VMZ20		VMZ25	
POM	PVDF	POM	PVDF	POM	PVDF	POM	PVDF	POM	PVDF
3 Nm	3 Nm	3 Nm	4 Nm	5 Nm	6 Nm	6 Nm	8 Nm	17 Nm	22 Nm

- ↪ Tighten both union nuts with the maximum torque.

## 5 Electrical connection

The electrical connection of the VMZ.2 is made via the 4-pin plug M12x1 at the top of the housing.

The wiring of the VMZ.2 depends on the ordered version. A distinction is made between frequency output or analogue output and frequency output.



### **CAUTION! Electric current!**

The electrical connection should only be carried out by a fully qualified electrician.

↳ De-energize the electrical system before connecting the VMZ.2.

#### **Connection cable:**

Suitable connection cables with moulded coupling socket M12x1 are available in different lengths as SIKKA accessories. The maximum permissible cable length is 10 m.

#### **Connection 4-pin plug M12x1:**

- ↳ Screw the coupling socket of the connection cable to the plug of the VMZ.2.
- ↳ Tighten the knurled nut of the coupling socket with a maximum torque of 1 Nm.

## 5.1 Wirings

### Pinout:

The pinout differs according to the chosen configuration of the device.

Pinout:

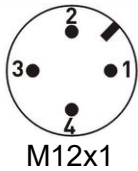

Possible pinout:

- Pin 1: +U<sub>B</sub>
- Pin 2: n. c. (not connected) / Analogue U/I
- Pin 3: GND
- Pin 4: Frequency

↪ Connect the connection cable according to your version and the pinout on the type plate.

### Supply voltage:

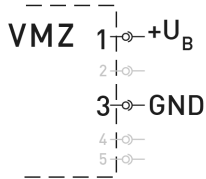

### VMZ.2 with frequency output:

#### Push-Pull:

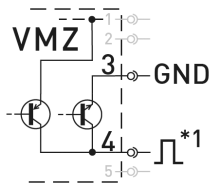

#### NPN Open Collector:

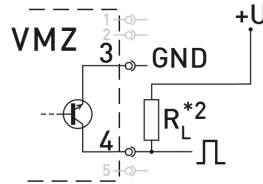

#### PNP Open Collector:

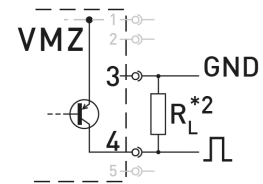

\*1: Push-Pull switching outputs of several VMZ.2 may not be connected in parallel.

\*2: Recommendation Pull-Up / Pull-Down resistance  $R_L \sim 2.5 \text{ k}\Omega$  (12 V) or  $\sim 5 \text{ k}\Omega$  (24 V).

Ensure that the maximum signal current of 25 mA is not exceeded.

### Use of frequency and analogue output

#### Push-Pull:

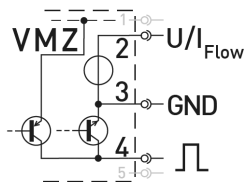

#### NPN Open Collector:

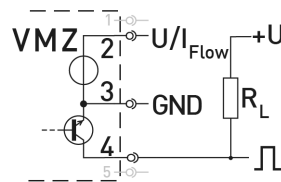

#### PNP Open Collector:

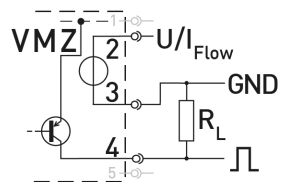

Recommendation for resistance  $R_L \sim 2.5 \text{ k}\Omega$  (12 V) or  $\sim 5 \text{ k}\Omega$  (24 V).

Ensure that the maximum signal current of 25 mA is not exceeded.

## 6 Commissioning and measuring operation

Before switching on the VMZ.2 for the first time, please follow the instructions in the following section.

### 6.1 Commissioning

Check that

- the VMZ.2 has been installed correctly and that all screw connections are sealed.
- the electrical wiring has been connected properly.
- the measuring system is vented by flushing.

### 6.2 Switching on and off

The VMZ.2 has no switch and cannot be switched on or off on its own. Switching on and off is carried out by the applied supply voltage.

↪ Switch on the supply voltage.

The green LED lights up. The VMZ.2 is ready and goes into measuring mode.

### 6.3 Measuring operation

In the measuring mode, the green LED flashes proportional to the measured flow.



For the human eye, the flashing is no longer visible from a frequency of ~30...40 Hz.

The green LED then seems to light up permanently.

#### VMZ.2 with frequency output:

The VMZ.2 provides according to the version a flow proportional NPN, PNP or Push-Pull square wave signal.

The frequency of the pulse output changes according to the flow (→ Fig.).

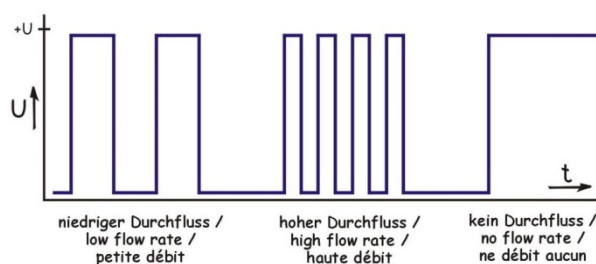

#### VMZ.2 with analogue output:

According to the configuration of the VMZ.2, the analogue output provides a voltage or current signal.

This signal is proportional to the measured flow. You will find the scaling of the analogue output on the type plate.

## 7 Maintenance and cleaning

### Maintenance:

The VMZ.2 is maintenance-free and cannot be repaired by the user. In case of a defect, the device must be replaced or sent back the manufacturer for repair.



### **CAUTION! Material damage!**

When opening the device, critical parts or components can be damaged.

↪ Never open the device and perform any repair yourself.

### Cleaning:

Clean the VMZ.2 with a dry or slightly damp lint-free cloth. Do not use sharp objects or aggressive agents for cleaning.

## 7.1 Return shipment to the manufacturer

Due to legal requirements placed on environmental protection and occupational safety and health and to maintain the health and safety of our employees, all units returned to SIKA for repair must be free of toxins and hazardous substances. That also applies to cavities in the devices. If necessary, the customer must neutralise or purge the unit before return to SIKA.

Costs incurred due to inadequate cleaning of the device and possible costs for disposal and/or personal injuries will be billed to the operating company.



### **WARNING! Risk of injury due to insufficient cleaning!**

The operating company is responsible for all damages and harm of any kind, in particular physical injuries (e.g. caustic burns or toxic contaminations), decontamination measures, disposal etc. that can be attributed to insufficient cleaning of the measuring instrument.

↪ Comply with the instructions below before returning the unit.

The following measures must be taken before you send the unit to SIKA for repair:

- ↪ Clean the device thoroughly. This is of extreme importance if the medium is hazardous to health, i.e. caustic, toxic, carcinogenic or radioactive etc.
- ↪ Remove all residues of the media and pay special attention to sealing grooves and slits.
- ↪ Attach a note describing the malfunction, state the application field and the chemical/physical properties of the media.
- ↪ Please follow the instructions on the procedure for sending returns which are on our website ([www.sika.net/en/service/service/rma-return-of-products](http://www.sika.net/en/service/service/rma-return-of-products)) and please specify a point of contact in case our service department has any questions.

## 8 Disassembly and disposal



### CAUTION! Risk of injury!

Never remove the device from a plant in operation.

↳ Make sure that the plant is shut down professionally.

### Before disassembly:

Prior to disassembly, ensure that

- the equipment is switched off and is in a safe and de-energised state.
- the equipment is depressurised and has cooled down.

### Disassembly:

- ↳ Remove the electrical connectors.
- ↳ Remove the VMZ.2 using suitable tools.

### Disposal:

Compliant with the Directives 2011/65/EU (RoHS) and 2012/19/EU (WEEE)\*, the device must be disposed of separately as electrical and electronic waste.



### NO HOUSEHOLD WASTE!

The VMZ.2 consists of various different materials. It must not be disposed of with household waste.

↳ Take the VMZ.2 to your local recycling plant

or

↳ send the VMZ.2 back to your supplier or to SIKA.

\* WEEE reg. no.: DE 25976360

## 9 Technical data

The technical data of customised versions may differ from the data in these instructions. Please observe the information specified on the type plate.

### 9.1 Characteristics VMZ.2

Type	VMZ03	VMZ06	VMZ08	VMZ15	VMZ20	VMZ25
<b>Measurement device characteristics</b>						
Flow range [l/min]	0.1...2	0.25..5	1...20	2.5...50	5...200	12.5...250
Accuracy*	±0.7 % of reading ±0.3 % of range					
Repeatability	±1%					
Output signal starting from [l/min]	0.05	0.1	0.25	1	4	5
Max. flow rate [l/min]	2.5	6	25	60	240	300
Response time	< 100 ms					
Indication	LED green, flow proportional flashing					
<b>Output signal characteristics</b>						
<b>Frequency output:</b>						
- Pulse rate / K-Factor [pulses/l]	10 000	4000	1000	400	200	80
- Resolution [ml/pulse]	0.1	0.25	1.0	2.5	5.0	12.5
- Signal shape	Square wave signal • duty cycle 50:50 Push-Pull • NPN open collector • PNP open collector					
- Signal current	≤ 100 mA					
<b>Analogue output 4...20 mA (optional)</b>						
Corresponds to flow rate [l/min]	0...2	0...5	0...20	0...50	0...200	0...250
Max. burden	250 Ω to GND					
<b>Analogue output 0.5...10 V (optional)</b>						
Corresponds to flow rate [l/min]	0...2	0...5	0...20	0...50	0...200	0...250
<b>Electrical characteristics</b>						
Supply voltage	12...24 V <sub>DC</sub> (±10 %) **					
Power consumption	Max 3.6 W					
Electrical protection measures	short-circuit proof • protected against polarity reversal					
Electrical connection	4-pin plug M12x1					
Degree of protection (EN 60529)	IP 65 (only with a connected coupling)					

\* test conditions: Water 23 °C

\*\* Voltage output 0.5...10 V only available with 16...24 VDC



Type	VMZ03	VMZ06	VMZ08	VMZ15	VMZ20	VMZ25
<b>Process variables</b>						
Medium to measure	Water and other conductive liquids					
- Conductivity	> 20 µS/cm					
- Temperature (PVDF measuring tube)	-15...80 °C (non-freezing)					
- Temperature (POM measuring tube)	-15...60 °C (non-freezing)					
Ambient temperature	-15...60 °C					
Storage temperature	-15...60 °C					
Nominal diameter	DN 3	DN 6	DN 8	DN 15	DN 20	DN 25
Inner diameter	3 mm	8 x 2 mm	8 mm	14 mm	18 mm	25 mm
Max. working pressure (at ... °C)	10 bar (20 °C) • 8 bar (40 °C) • 6 bar (60 °C) • 5 bar (80 °C)					
Process connection - male thread	G $\frac{3}{8}$ B	G $\frac{1}{2}$ B	G $\frac{1}{2}$ B	G $\frac{3}{4}$ B	G1 B	G1 $\frac{1}{4}$ B

## 9.2 Materials table

Component	Material	Component-wetted
Housing	ABS	
Measuring tube	POM or PVDF (option)	<b>X</b>
Process connections	POM or PVDF (option)	<b>X</b>
O-ring	EPDM or FKM (option)	<b>X</b>
Electrodes and earthing rings	Stainless steel 1.4404 or Hastelloy C®	<b>X</b>

### 9.3 Dimensions

#### VMZ.2 DN 3 / DN 6 / DN 8 / DN 15 / DN 20:

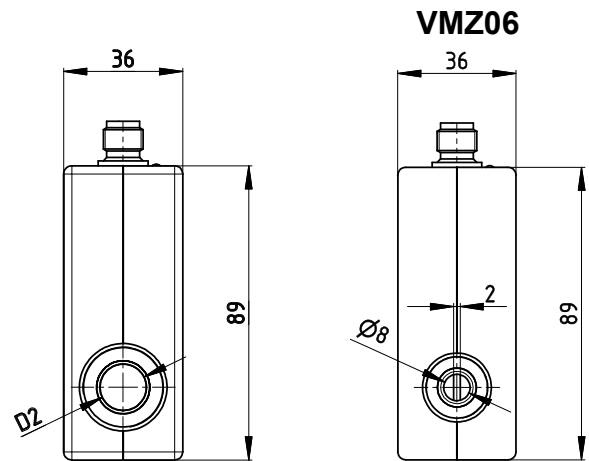
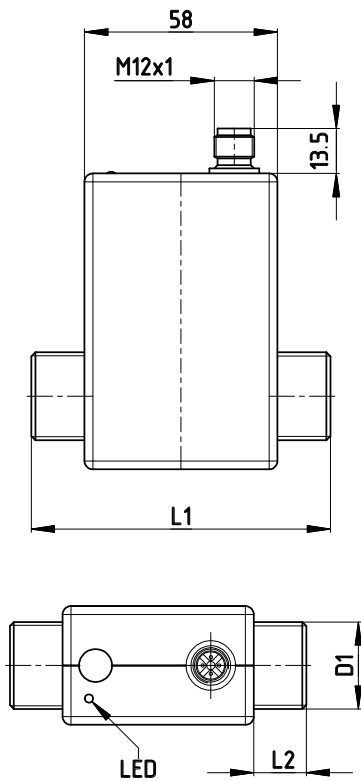

Type	L1	L2	D1	D2
VMZ03	85	13	G $\frac{3}{8}$ B	Ø 3
VMZ06	85	13	G $\frac{1}{2}$ B	Ø 8 x 2
VMZ08	85	13	G $\frac{1}{2}$ B	Ø 8
VMZ15	90	16	G $\frac{3}{4}$ B	Ø 14
VMZ20	90	16	G1 B	Ø 18

#### VMZ.2 DN 25:

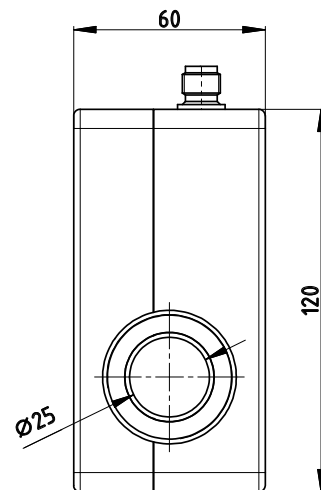
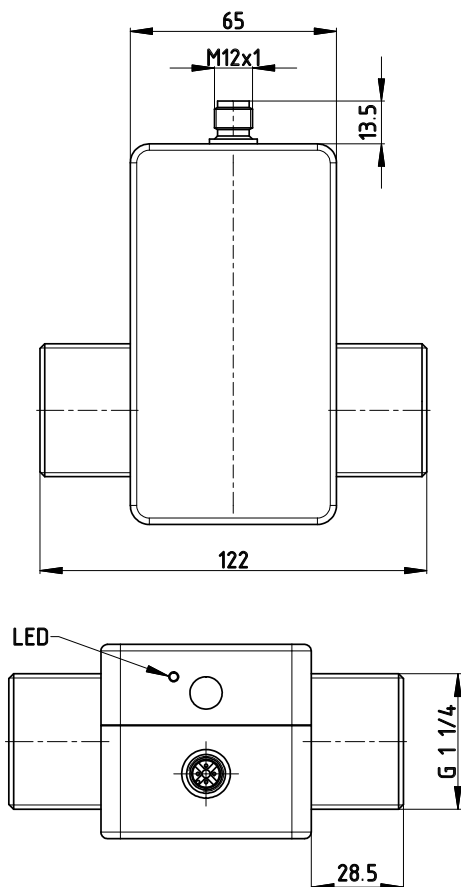

**For your notes**



**SIKA Dr. Siebert & Kühn GmbH & Co. KG**

Struthweg 7–9

34260 Kaufungen / Germany

 +49 5605 803-0

 +49 5605 803-555

[info@sika.net](mailto:info@sika.net)

[www.sika.net](http://www.sika.net)

© SIKA • Ba\_VMZ.2\_en • 06a/2021