

INSTRUCTIONS AND MAINTENANCE MANUAL

FLOAT LEVEL

Read and understand the operating instruction before starting any work. Keep the instruction for later use.

1 GENERAL INFORMATION

1.1 Functional description

The principle of operation of these instruments is based on the drive of one or more magnetic reed contacts placed inside the measuring rod. They are activated by a permanent magnet located within a float, which changes its height with the media to be measured. A float level switch can consist of one or more floats, which may move between their upper and lower stops. The electrical switches are sealed inside the supporting stem and are magnetically actuated by the floats. The position of the switches are previously defined and cannot be modified by the user. A continuous float level instrument consists of one float moving along the whole stem length between the upper and lower stop.

- | | |
|---------------------------|----------------|
| 1 – Electrical connection | 4 – Float |
| 2 – Process connection | 5 – Float stop |
| 3 – Stem | |

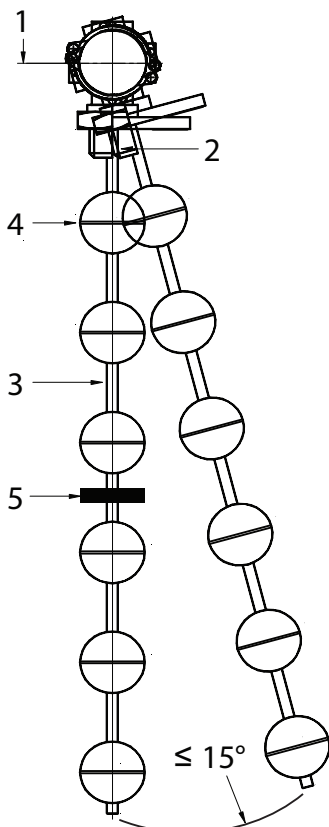

1.2 Intended use

This type of float levels can be used exclusively for monitoring the levels of liquid media.

- Do not use with liquids with large contamination and liquids that can crystallize.
- Do not use with liquids that are not compatible with the contact parts.
- Do not use with abrasive liquids, highly viscous media and colors.
- Do not use in hazardous areas.
- Do not use near ferromagnetic environments.
- Do not use near strong electromagnetic fields or in the immediate vicinity of equipment that can be affected by magnetic fields.
- Do not use with heavy mechanical strain.

Trafag shall not be liable for claims of any type based on operation contrary to the intended use.

This float levels must be used only by skilled personnel with appropriate education and training.

1.3 Improper use

Any use beyond or different to the intended use is considered as improper use.

Do not use this float levels as safety or emergency stop devices.

2 COMMISSIONING AND MOUNTING

- Mount the instruments on the process connection according the respective standards.
- If the instruments must be inserted from the top of the tank, but the float(s) do not fit through the opening, the float(s) may be removed for mounting.

Make sure (e.g. through appropriate marking) to reassemble the floats correctly after the installation of the process connection.

3 ELECTRICAL CONNECTION

The reed contacts within these instruments may carry and up to 100.000 operations.

WIRING OF THERMOSTAT is always connected to the last terminals after standard wiring.

FLOAT LEVEL SWITCH AND FLOAT LEVEL SENSOR

TYPE: TFS, TFC

3.1 TFS - Float level switches

3.1.1 DIN43650 A plug

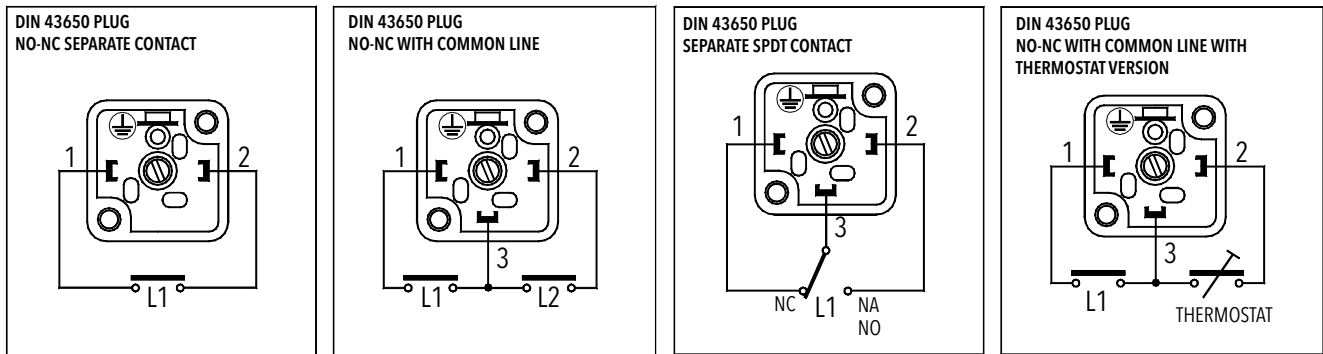

3.1.2 Terminal box

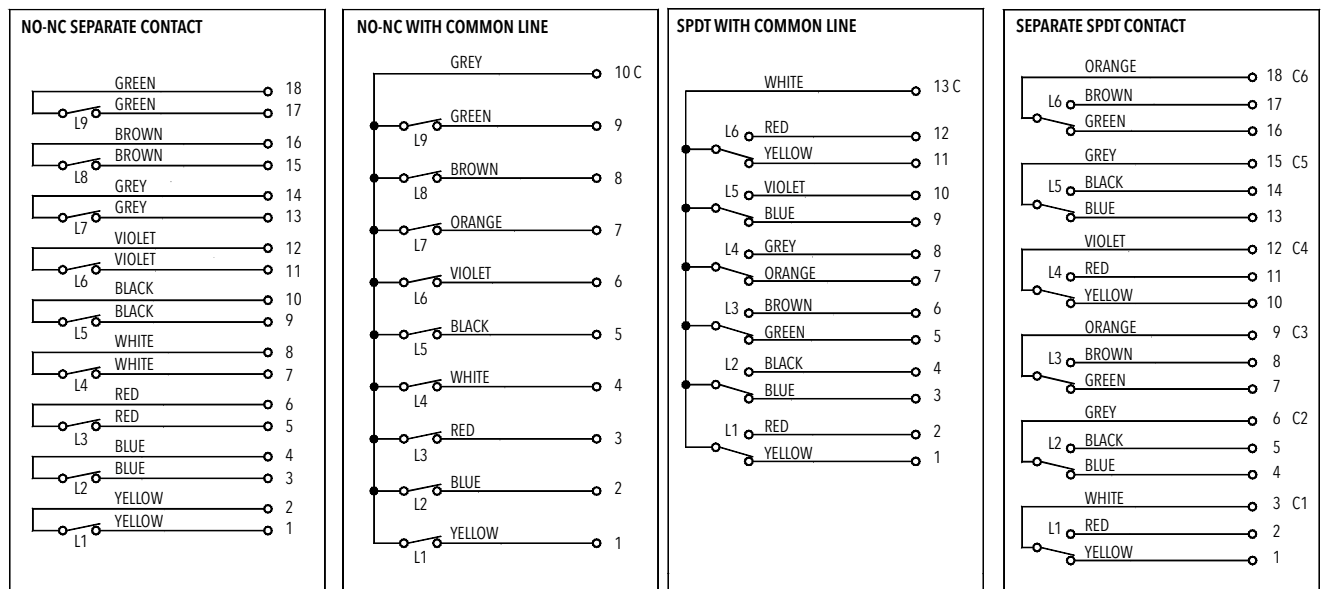

FLOAT LEVEL SWITCH AND FLOAT LEVEL SENSOR

TYPE: TFS, TFC

3.1.3 Cable (PVC or Silicon)

1 Switch

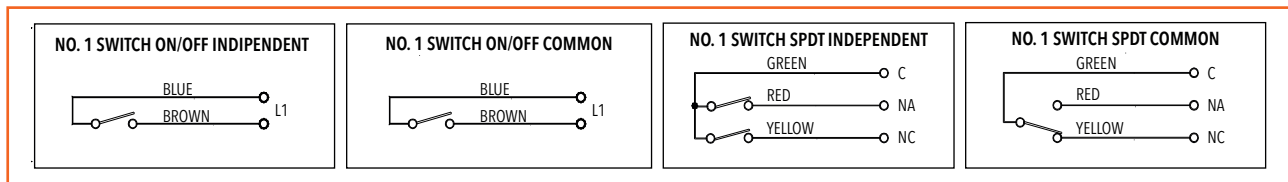

2 Switches

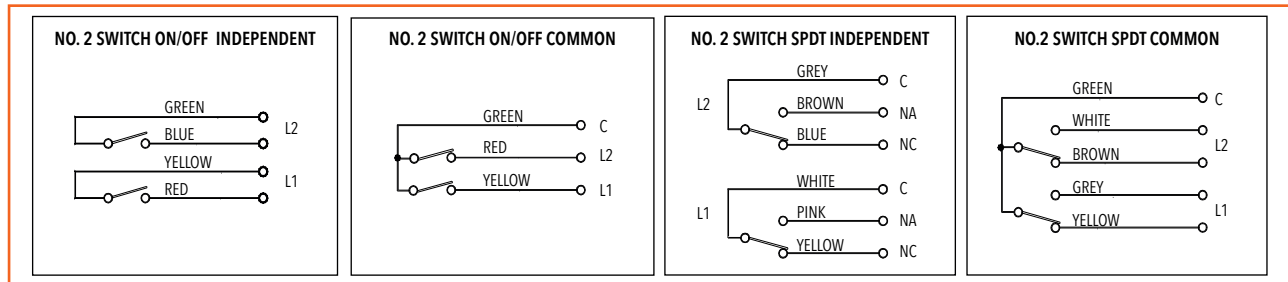

3 Switches

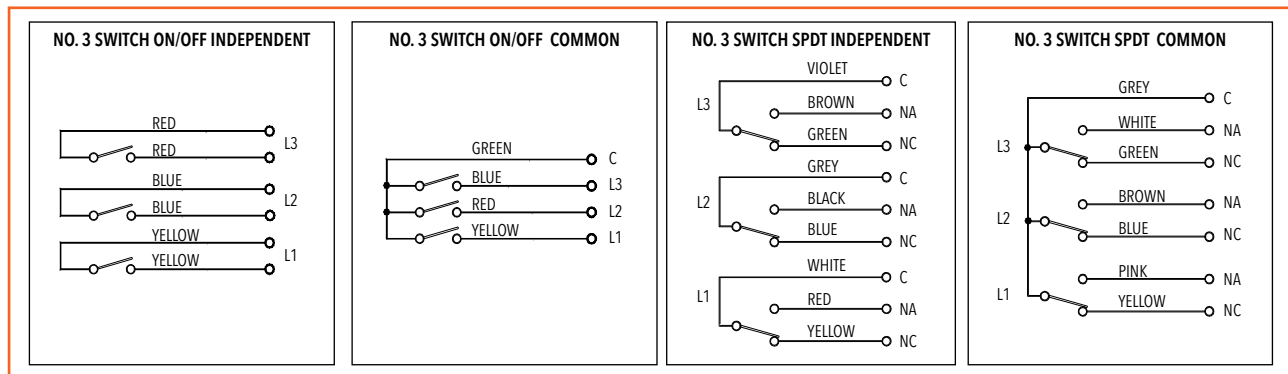

4 Switches

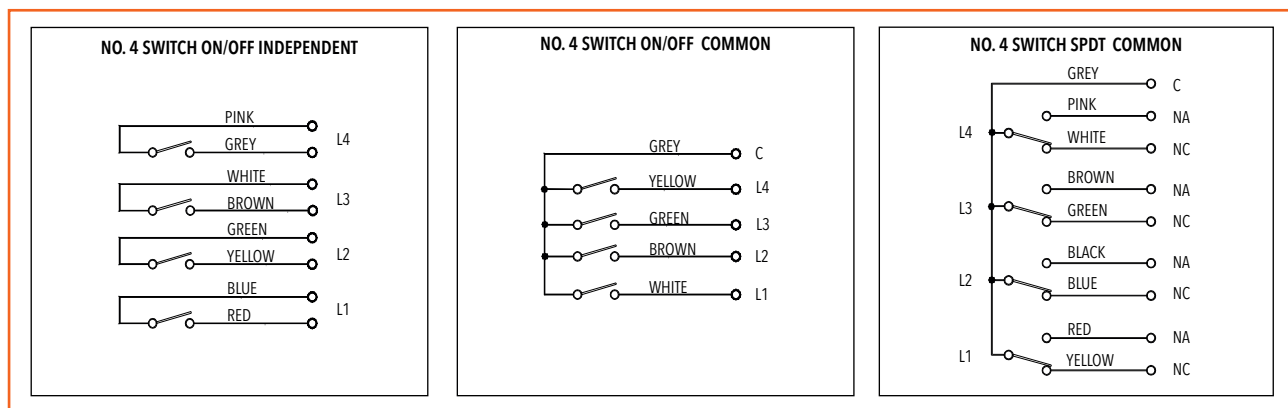

5 Switches

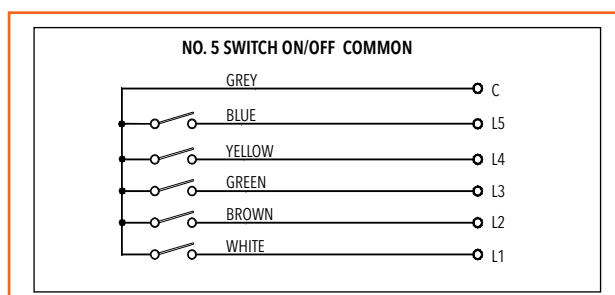

6 Switches

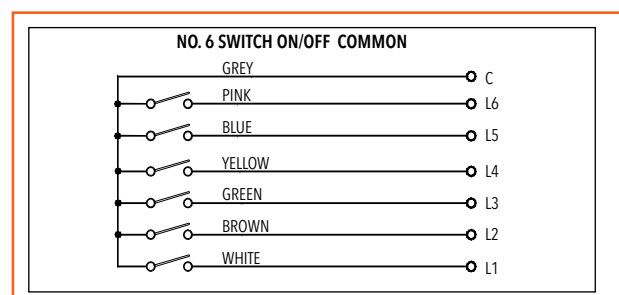

NOTE: In most configurations, it is possible to invert the switch made from NC to NO and vice-versa by turning the floats.

FLOAT LEVEL SWITCH AND FLOAT LEVEL SENSOR

TYPE: TFS, TFC

3.2 TFC – Continuous float level

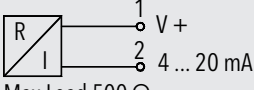
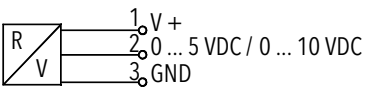
Electrical connection type					
		W1	S1	P1	P2
Output type	<p>4 ... 20 mA OUTPUT</p>  <p>Max Load 500 Ω Power supply 18 ... 36 VDC</p>	Supply (+)_ Jack 1 Out (-)_ Jack 2	Supply (+)_ PIN1 Out (-)_ PIN2	Supply (+)_ RED Out (-)_ BLUE	Supply (+)_ RED Out (-)_ BLUE
	<p>0 ... 5 / 0 ... 10 VDC OUTPUT</p>  <p>Max Load 500 Ω Power supply 18 ... 30 VDC</p>	Supply (+)_ Jack 1 Out (-)_ Jack 2 GND _ Jack 3	Supply (+)_ PIN 1 Out (-)_ PIN 2 GND _ PIN 3	Supply (+)_ RED Out (-)_ YELLOW GND _ GREEN	Supply (+)_ RED Out (-)_ YELLOW GND _ GREEN

4 MAINTENANCE AND CLEANING

- When using properly, the instruments does not need any particular maintenance
- Repairs must only be carried out by the manufacturer
- External cleaning of the instruments could be done by using a moist cloth
- Do not use any aggressive cleaning agents
- Electrical connections must not come into contact with moisture

5 DISPOSAL

Dispose of instrument components and packaging materials in an environmentally compatible way and in accordance with the country-specific waste disposal regulations.

Additional information			
Documents	Instructions	H21040	www.trafag.com/H21040
	Data sheet	H20040	www.trafag.com/H20040
		H20041	www.trafag.com/H20041